



*UP TO 30% MORE HORSEPOWER  
10-20% FUEL SAVINGS*

— 3.1L YANMAR TIER IV FINAL  
ENGINES —

# YM3104 MODULE INSTALLATION GUIDE



[AGDIESELSOLUTIONS.COM](http://AGDIESELSOLUTIONS.COM)





For Tech Support Please Call  
812-618-9168

## Switch Settings

Position 1- Stock (counter clockwise)

Position 2- Low- Up to 15% HP

Position 3- High- Up to 30% HP

\*Mechanical switch will  
override use of App settings

OR

Download the Ag Diesel Connect  
App on your Android or iOS  
devices using the code below, or  
by searching "Ag Diesel  
Connect" in your app store.



Module switch can be ran inside the cab for easy  
performance adjustment. Module switch can be  
secured in engine bay if desired. Module will default  
to HIGH setting if switch is not connected.

\*NOT FOR USE IN CALIFORNIA\*

\*MODULE DOES NOT BYPASS, DELETE, OR DEFEAT ANY EMISION CONTROL SYSTEMS\*

\*If installation assistnace is needed, Ag Diesel Solutions is not responsible for any cost associated  
with third party installation.

Your equipment will return to stock power by  
removing the module from our harness

**WWW.AGDIESELSOLUTIONS.COM**

**\*NOTE: Do not change performance settings while equipment is under load**

NOT FOR USE IN CALIFORNIA\*

\*MODULE DOES NOT BYPASS, DELETE, OR DEFEAT ANY EMISSIONS CONTROL SYSTEMS\*

If installation assistance is needed, Ag Diesel Solutions is not responsible for any cost associated  
with a third party installation.

## 3.1L Final Tier 4 Yanmar Module Installation Instructions

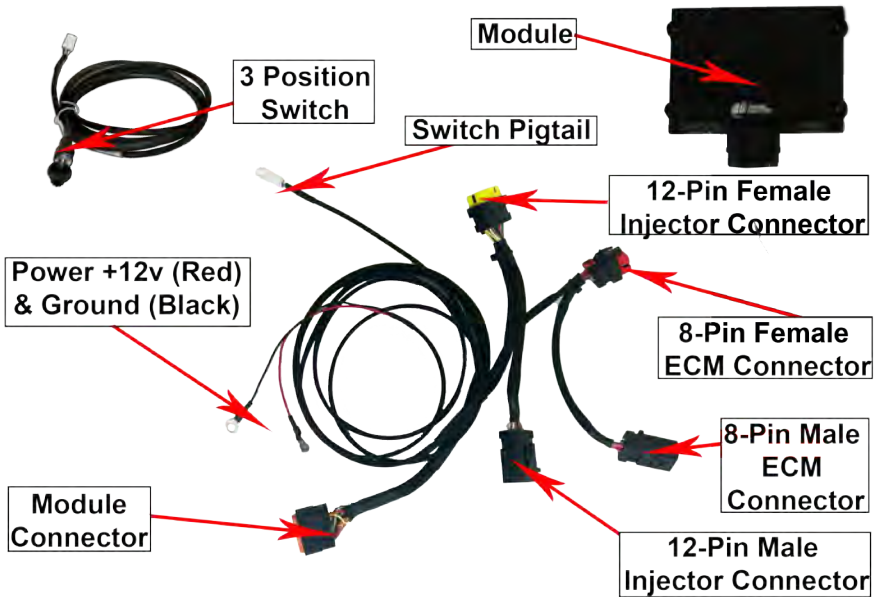

1) Gain access to injector connectors by lifting the cab. Remove the two nuts holding it down using a socket wrench with 18mm socket. Make sure to lift cab until it locks in the upright position.



**2)** Locate the two injector connectors to the right side of the hydraulic fluid tank as facing the front of the machinery.



**3)** Unplug the two factory injector connectors shown by pulling back on the lock tab and depressing the release just forward of the lock. One connector will be a 12 pin with yellow insert, the other 8 pin with a red insert.

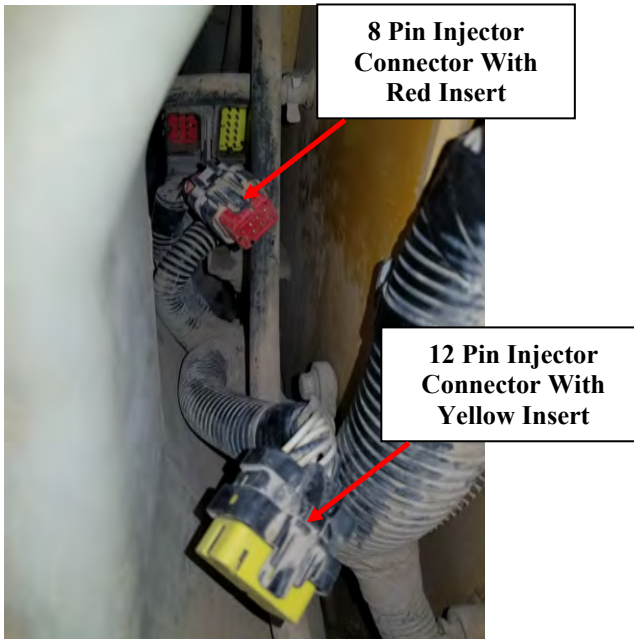

4) Plug the female injector connectors from the ADS harness into factory injector controller. Match the pin count and color to the factory controller.

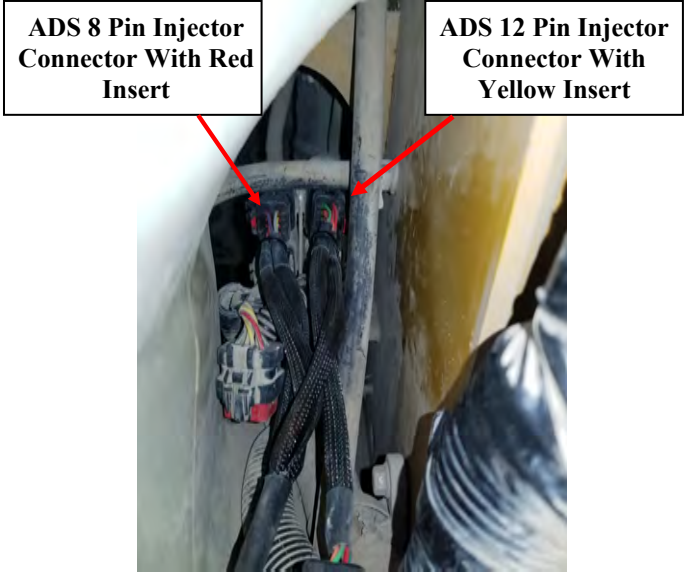

5) Plug the male ADS injector connectors into the factory female injector connectors. Again matching pin count and insert color.

**Note:** Insure connectors seat all the way with audible "click".





**6)** Route power and ground leads along factory wiring loom to the battery. Connect red wire with ring terminal to positive battery post. Connect the Black wire with ring terminal to negative battery post.



**7)** Mount the module with the connector on the bottom side, as to reduce the chance of moisture from getting into the module harness. Keep away from excessive heat and moving parts.

Note: Zip tie onto the factory computer wire harness works well. Mounting the module as shown will help prevent moisture from collecting into the module connector.



For any  
questions on  
this installation  
please call Tech  
Support at  
812.618.9168







## **Why Ag Diesel Solutions Modules ?**

*Saving More Fuel Per Hour with 10-20% Returns  
Getting More Done -- Up to 30% More Horsepower and Torque*

*No Programming of the Factory ECM or Changes to Fuel Pressure*

*Linear Based Load Technology - Only Giving Power when You Need It*

*Peace of Mind with USA Based Tech Support and  
a 30 Day Money Back Guarantee*

*No Loss of Product Benefits if Factory Tuning is Required  
Reduce Downtime - Install Yourself - No Tech Needed*

*Transferable to New Machines with Same Engine  
Does Not Defeat or Delete Any Engine Components*

*Quality Manufacturing to Withstand a LIFETIME on the Farm*



***AgDieselSolutions.com***

Engineered, Manufactured, Tested and Proven in the

***U.S.A***

Industry Leading 3 Year WARRANTY



**AG**

**DIESEL  
SOLUTIONS**

FARM SMART. FARM EFFICIENT.

# THIS IS A HIGH PERFORMANCE PRODUCT. USE AT YOUR OWN RISK.

Do not use this product until you have carefully read the following agreement. This sets forth the terms and conditions for the use of this product. The installation of this product indicates that the BUYER has read and understands this agreement and accepts its terms and conditions

## DISCLAIMER OF WARRANTY AND LIMITATION OF LIABILITY

PSI Power, Inc and its successors, distributors, jobbers, and dealers (hereafter "SELLER") shall in no way be responsible for the product's proper use and service. It is the installer's responsibility to check for proper installation and if in doubt, contact the manufacturer. The SELLER assumes no liability regarding the improper installation or misapplication of its products. BUYER ACKNOWLEDGES IT HAS HAD THE OPPORTUNITY TO FULLY INSPECT THE PRODUCT. ACCORDINGLY, BUYER ACKNOWLEDGES THAT THE PRODUCT IS BEING SOLD IN "AS IS/WHERE IS" CONDITION AND WITH ALL FAULTS. EXCEPT AS OTHERWISE PROVIDED HEREIN, THERE ARE NO EXPRESS WARRANTIES WITH RESPECT TO THE GOODS, AND ALL IMPLIED WARRANTIES, INCLUDING BUT NOT LIMITED TO, IMPLIED WARRANTIES OF FITNESS FOR A PARTICULAR PURPOSE AND MERCHANTABILITY ARE LIKEWISE HEREBY EXPRESSLY AND FULLY DISCLAIMED. SELLER SHALL NOT BE HELD LIABLE FOR SPECIAL, INDIRECT, INCIDENTAL OR CONSEQUENTIAL DAMAGES OF ANY NATURE WITH RESPECT TO THE PRODUCTS (INCLUDING, WITHOUT LIMITATION, LOST PROFITS, LOST SALES, LOSS OF PRODUCTION, PROPERTY DAMAGE, PERSONAL INJURY OR LOSS OR DAMAGE RESULTING FROM INTERRUPTION OR FAILURE IN OPERATION OF THE PRODUCTS) AND BUYER HEREBY EXPRESSLY WAIVES AND DISCLAIMS ALL SUCH LIABILITY CLAIMS. THE BUYER ACKNOWLEDGES AND AGREES THAT THE DISCLAIMER OF LIABILITY CONTAINED HEREIN IS A MATERIAL TERM OF THE SALE OF THE PRODUCT AND, TO THE FULLEST EXTENT PERMITTED BY LAW, BUYER SHALL DEFEND, INDEMNIFY AND HOLD SELLER HARMLESS FROM ANY AND ALL CLAIMS, DEMANDS, CAUSES OF ACTION, CONTROVERSIES, LIABILITIES, FINES, LOSSES, COSTS AND EXPENSES (INCLUDING, BUT NOT LIMITED TO ATTORNEYS' FEES, EXPERT WITNESS EXPENSES AND LITIGATION EXPENSES) ARISING FROM OR RELATED TO SELLER'S PRODUCTS.

## LIMITED 3 YEAR WARRANTY

PSI Power, INC. (hereafter "SELLER") warrants that the product supplied shall conform to SELLER's specifications and shall be free from defects in design, material or workmanship for 3 years to the original BUYER. This warranty shall not be extended, transferred, assigned or varied except by a written instrument signed by SELLER and BUYER. Products that have been returned to SELLER during the warranty period and accompanied by a dated proof of purchase receipt, with shipping and handling paid by the BUYER, and found to be defective in design, material, or workmanship, in SELLER's sole discretion, may be repaired or replaced at SELLER's option and cost. All warranty claims hereunder are subject to approval by SELLER upon examination of the product. If the product is found not to be defective by SELLER, the product may be returned to BUYER at BUYERS cost. Under no circumstances shall the SELLER be liable for any labor charged or travel time incurred in diagnosis for defects, removal, or reinstallation of this product or any other expenses. This warranty is void on any products that show evidence of misapplication, negligence, improper installation, abuse, lack of proper maintenance or alteration from its original design.

IN THE EVENT THAT THE BUYER DOES NOT AGREE WITH THIS AGREEMENT, THE BUYER MAY PROMPTLY RETURN THIS PRODUCT, IN A NEW AND UNUSED CONDITION, IN THE ORIGINAL PACKAGING, WITH A DATED PROOF OF PURCHASE, TO THE PLACE OF PURCHASE WITHIN (30) DAYS FROM THE DATE OF PURCHASE FOR A FULL REFUND. THE INSTALLATION OF THIS PRODUCT INDICATES THAT THE BUYER HAS READ AND UNDERSTANDS THIS AGREEMENT AND ACCEPTS ITS TERMS AND CONDITIONS

Effective 11/1/2022



- UP TO 30% HORSEPOWER INCREASE
- UP TO 10%–20% IN FUEL SAVINGS
- DOES NOT FLASH THE FACTORY ECM
- FIELD TESTED & DYNO PROVEN
- PLUG & PLAY INSTALLATION

Performance Electronics for Agriculture, Forestry, Construction, Pick-Up Trucks, Medium Duty Trucks, RVs, Heavy Duty Semis , and more!



LEARN MORE: [AGDIESELSOLUTIONS.COM](http://AGDIESELSOLUTIONS.COM)

